

FIG. 1

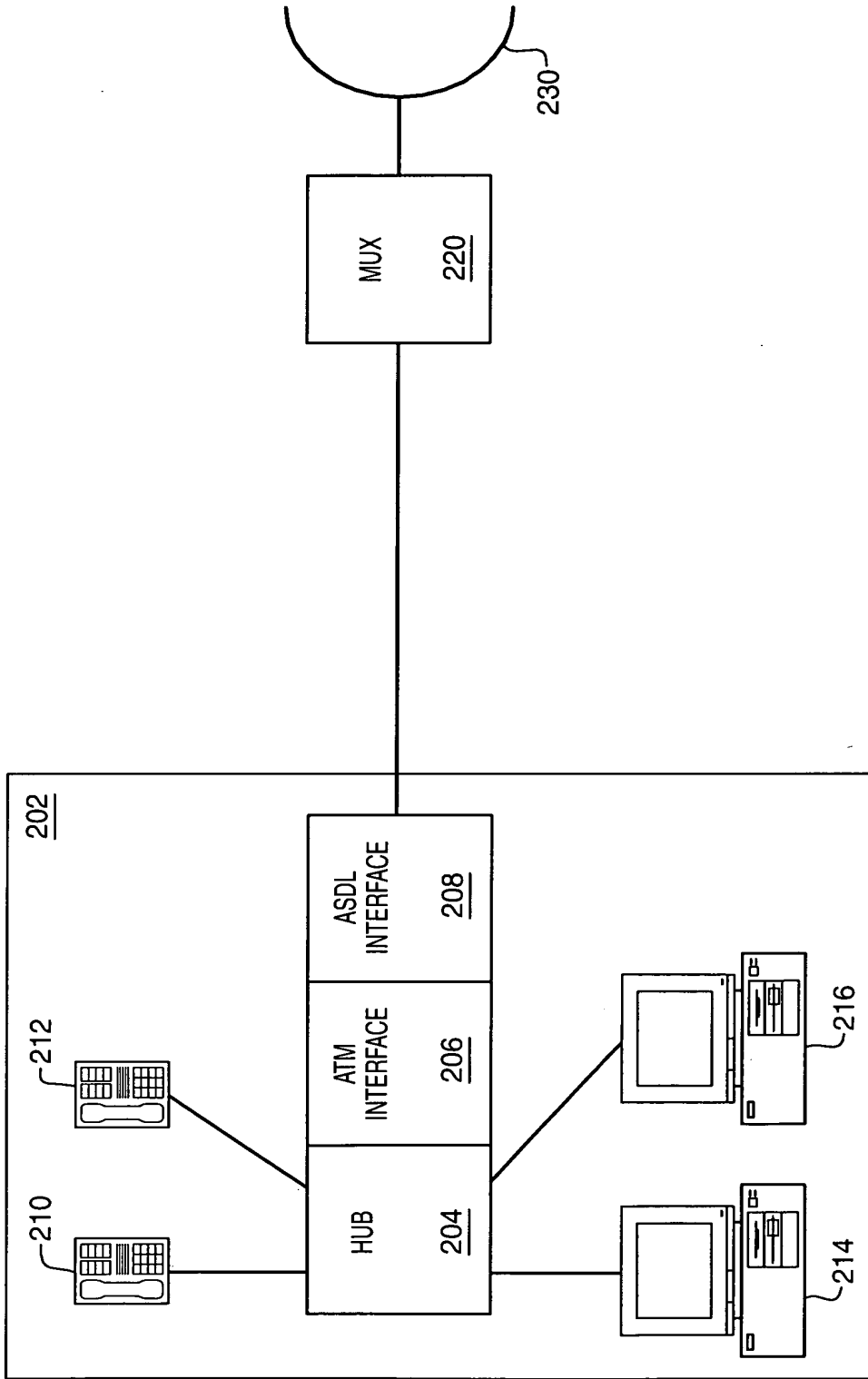
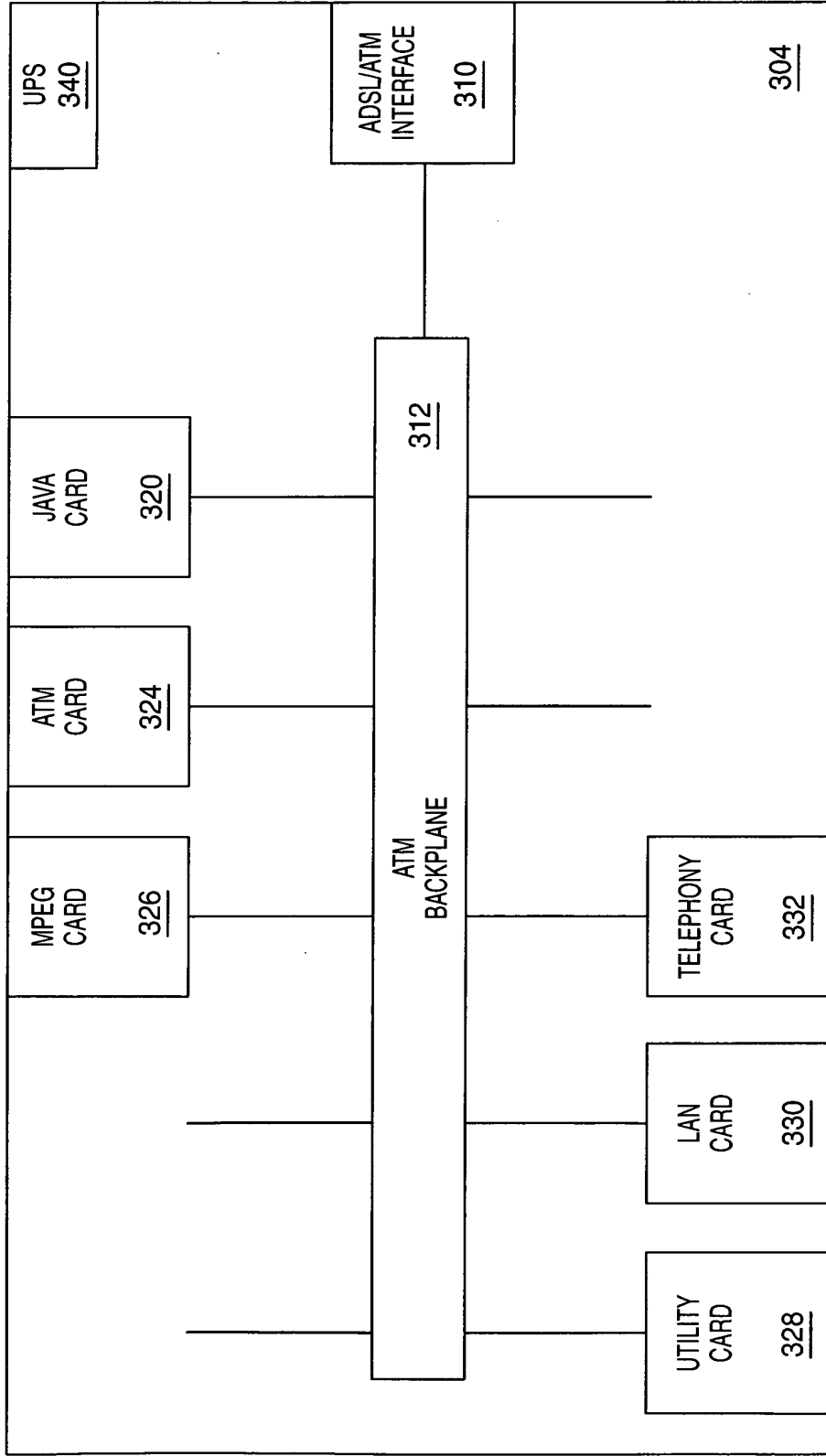
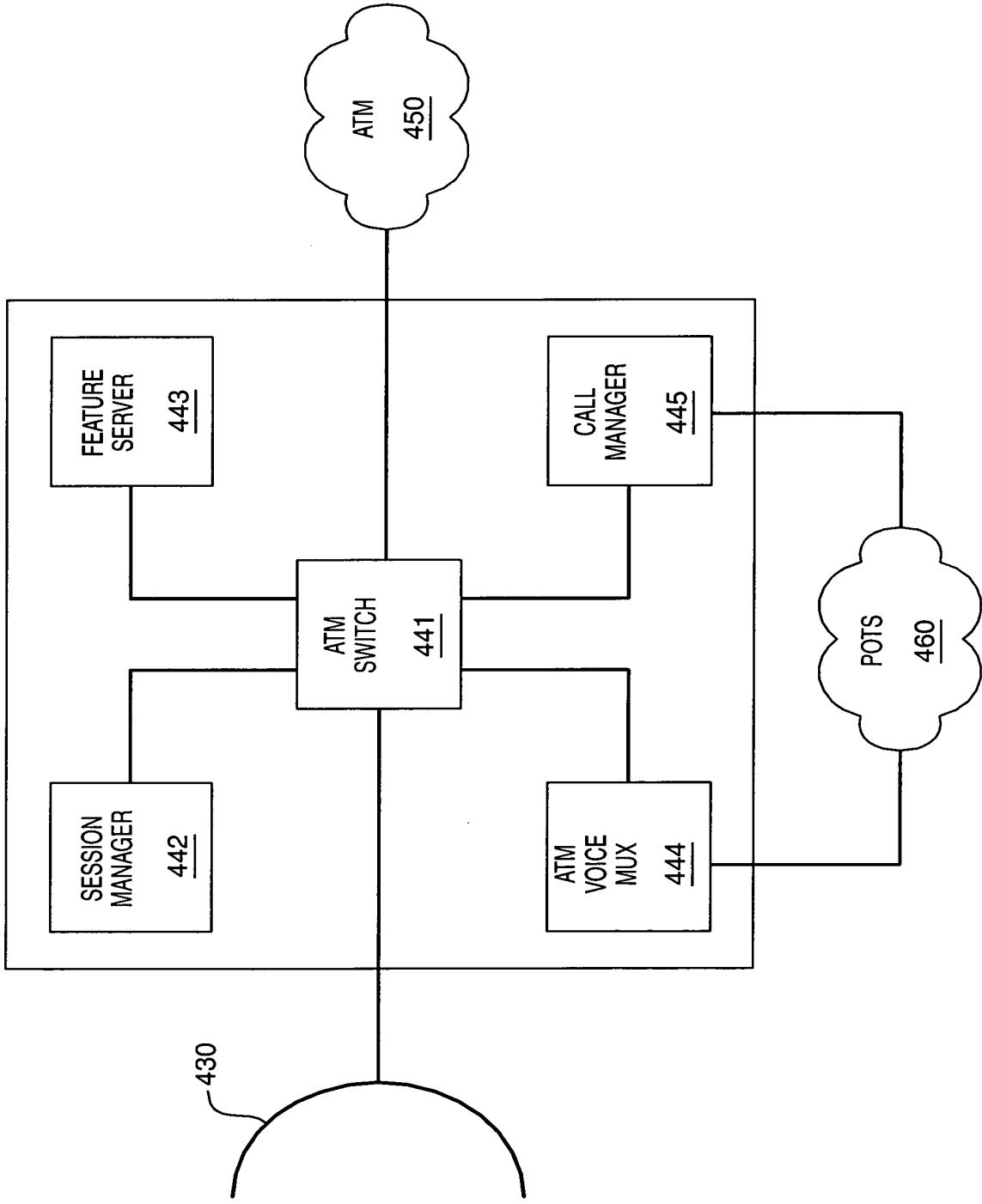

FIG. 2

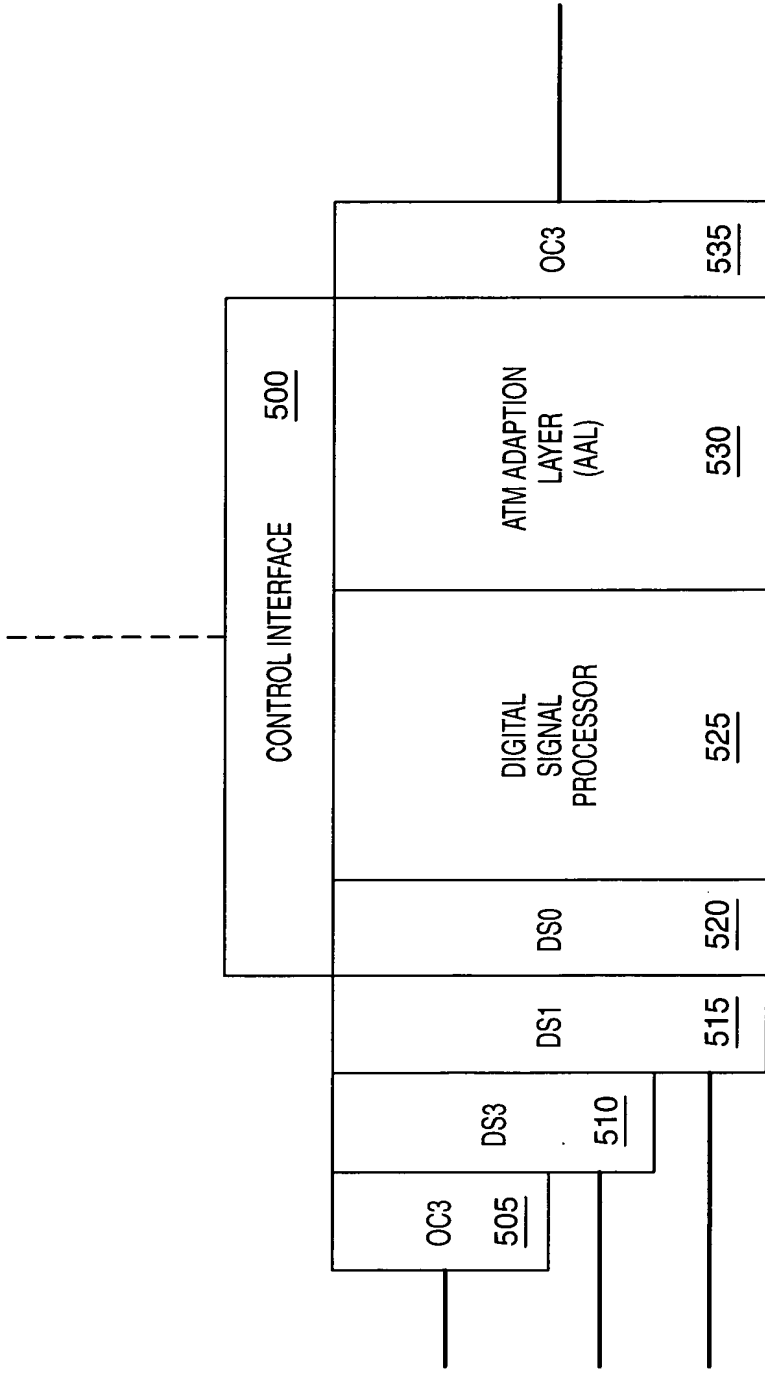

**FIG. 3**

FIG. 4



**FIG. 4**



**FIG. 5**

600 630 610 620

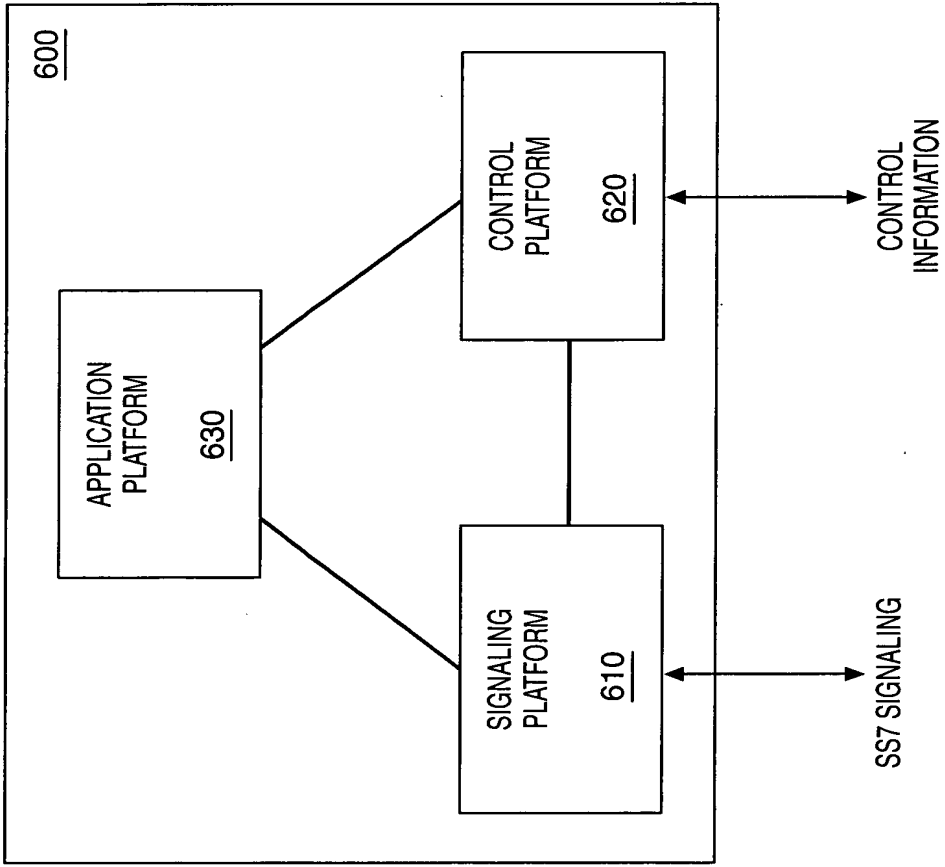

FIG. 6



3366 760900

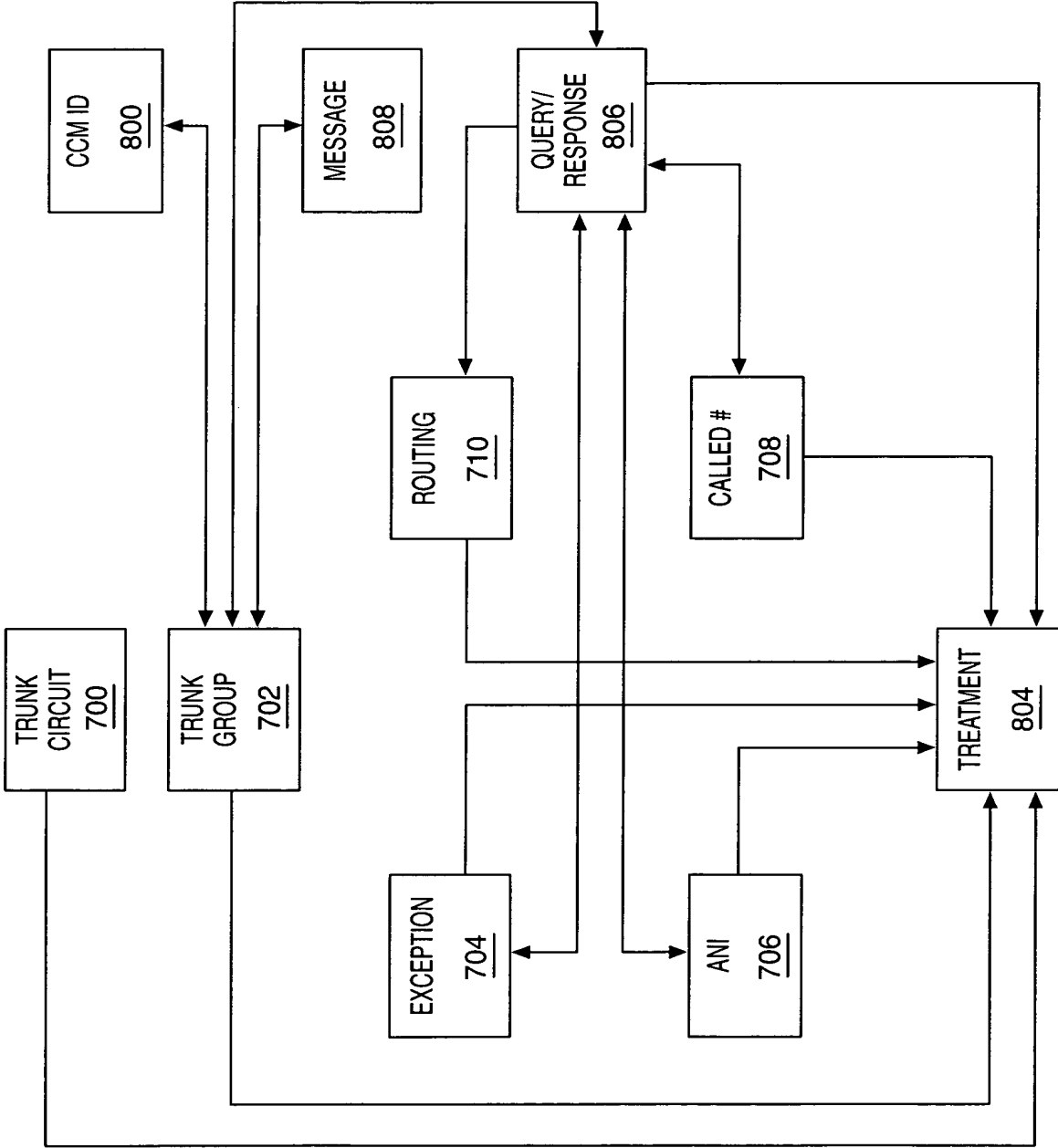

FIG. 8



ASSOCIATED POINT CODE	CIC	VP	VC	TRUNK GROUP NUMBER	GROUP MEMBER NUMBER	HARDWARE IDENTIFIER	ECHO CANCELLER	ECHO CONTROL	SATELLITE INDICATOR	CIRCUIT STATUS	CIRCUIT STATE	TIME/ DATE

**FIG. 9**

TRUNK GROUP NUMBER	GLARE RESOLUTION	CONTINUITY CONTROL	CLLI	SATELLITE TRUNK GROUP	SERVICE INDICATOR	ASSOCIATED NPA	SELECTION SEQUENCE	HOP COUNTER	ACC ACTIVE	OMI	NEXT FUNCTION	INDEX

**FIG. 10**

EXCEPTION TABLE INDEX	CARRIER SELECTION IDENTIFICATION	CARRIER IDENTIFICATION	CALLED PARTY		NEXT FUNCTION	INDEX
			NATURE OF ADDRESS	DIGITS FROM TO		

**FIG. 11**

ANI TABLE INDEX	CALLING PARTY CATEGORY	NATURE OF ADDRESS	CALLING PARTY/CHARGE NUMBER			ORIGINATING LINE INFORMATION	NEXT FUNCTION	NEXT INDEX
			DIGITS FROM	DIGITS TO	DATA			

**FIG. 12**

CALLED NUMBER TABLE INDEX	NATURE OF ADDRESS	DIGITS FROM	DIGITS TO	NEXT FUNCTION	NEXT INDEX

**FIG. 13**

ROUTING TABLE INDEX	TRANSIT NETWORK SELECTION				CIRCUIT CODE	NEXT FUNCTION #1	INDEX #1	NEXT FUNCTION #2	INDEX #2	NEXT FUNCTION #3	INDEX #3
	NETWORK IDENTIFICATION PLAN	DIGITS FROM	DIGITS TO	DIGITS TO							

**FIG. 14**

INDEX	MESSAGE RECEIVED CAUSE VALUE	GENERAL LOCATION	CODING STANDARD	CAUSE VALUE	NEXT FUNCTION	INDEX

**FIG. 15**

**FIG. 16**

MESSAGE TYPE	PARAMETERS	INDEX #1	INDEX #...	INDEX #N
ADDRESS COMPLETE	BACKWARD CALL INDICATOR			
	ACCESS TRANSPORT			
	CAUSE INDICATOR			
	OPTIONAL BACKWARD CALL INDICATORS			
	OPTIONAL "FE" INDICATOR			
ANSWER	ACCESS TRANSPORT			
	BACKWARD CALL INDICATOR			
CALL PROGRESS	EVENT INFORMATION			
	BACKWARD CALL INDICATOR			
	ACCESS TRANSPORT			
	CAUSE INDICATOR			
	OPTIONAL BACKWARD CALL INDICATOR			
CIRCUIT RESERVATION	NATURE OF CONNECTION INDICATOR			
CIRCUIT RESERVATION ACK	N/A			
CONFUSION	N/A			
CONTINUITY	CONTINUITY INDICATOR			
EXIT	OUTGOING TRUNK GROUP NUMBER			
INFORMATION	ALL PARAMETERS			
INFORMATION REQUEST	ALL PARAMETERS			
INITIAL ADDRESS	NATURE OF CONNECTION INDICATOR			
	FORWARD CALL INDICATOR			
	CALLING PARTY'S CATEGORY			
	USER SERVICE INFORMATION			
	CALLED PARTY NUMBER			
	ACCESS TRANSPORT			
	CALLING PARTY NUMBER			
	CARRIER IDENTIFICATION			
	CARRIER SELECTION INFORMATION			
	CHARGE NUMBER			
	GENERIC ADDRESS			
	ORIGINATING LINE INFORMATION			
	ORIGINAL CALLED NUMBER			
	REDIRECTING NUMBER			
	SERVICE CODE			
TRANSIT NETWORK SELECTION				
HOP COUNTER				
PASS ALONG	ALL PARAMETERS			
RELEASE	CAUSE INDICATOR			
	ACCESS TRANSPORT			
	AUTOMATIC CONGESTION CONTROL			
RELEASE COMPLETE	N/A			
RESUME	SUSPEND/RESUME INDICATOR			
SUSPEND	SUSPEND/RESUME INDICATOR			

1  
2  
3  
4  
5  
6  
7  
8  
9  
10  
11  
12  
13  
14  
15  
16  
17  
18  
19  
20  
21  
22  
23  
24  
25  
26  
27  
28  
29  
30  
31  
32  
33  
34  
35  
36  
37  
38  
39  
40  
41  
42  
43  
44  
45  
46  
47  
48  
49  
50  
51  
52  
53  
54  
55  
56  
57  
58  
59  
60  
61  
62  
63  
64  
65  
66  
67  
68  
69  
70  
71  
72  
73  
74  
75  
76  
77  
78  
79  
80  
81  
82  
83  
84  
85  
86  
87  
88  
89  
90  
91  
92  
93  
94  
95  
96  
97  
98  
99  
100